

Henderson

MARK E

SINGLE AXLE DUMP BODY



Henderson
Heavy-Duty Material Hauling Capabilities

The Dependable Ones™

All photos shown with optional equipment.

MARK E™

SINGLE AXLE DUMP BODY

A. Choose A Hoist Configuration

Start by selecting a hoist. The hoist controls a number of factors: appearance, function, placement, capacity and mounting height.

Underbody Hoist (A-1): a traditional hoist and sub-frame. It stows underneath the body, providing a clean and clear head sheet.

Telescopic Hoist (A-2): available with internal or external mounting and single (power up) or double (power up and down) acting function. Our telescopic hoist packages offer the lowest possible mounting height (low center of gravity). The external telescopic hoist has the option of adding a full width cradle assembly which holds the hydraulic reservoir and valve enclosure. This provides a central location for your hydraulic components positioned conveniently between the cab and head sheet.

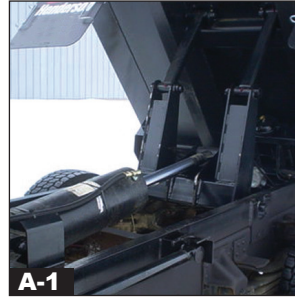

B. Choose A Side/Brace Configuration

Now we'll focus on appearance, side wall strength and ease of clean out. Remember to inquire about all available options. These options include walk rails, tarp rails, ladders, brackets and many more.

Smooth Sides (B-1): the basic style offered, reducing weight and cost. This design offers excellent strength and resistance to wear. Additional benefits include easy clean out and ideal advertising space. Proudly display your company logo or corporate message.

V-Crimp (B-2): the next level in side configuration. Designed to increase side wall strength and help maintain its outward appearance. Side walls may allow up to two v-crumps.

Weld-on Horizontal Brace (B-3): our "Top of the Line" side wall. This single weld-on brace runs the length of the body. It maintains smooth inside walls (easy clean out), provides the ultimate in side wall strength and is ideal for maintaining the body's outward appearance.

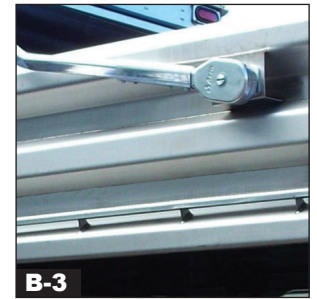
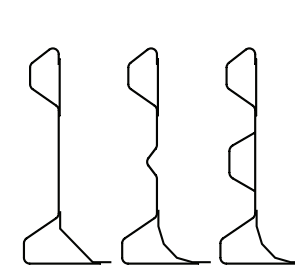
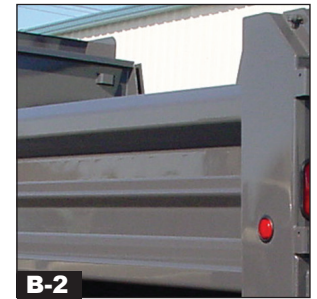

C. Choose A Side Profile

Side profile will determine your load hauling capacity and whether that capacity is fixed or flexible.

Straight Sides (C-1): the basic style offered. Like smooth sides, this option helps trim both weight and cost. It also provides the ability to add sideboard inserts (increased capacity). Steel sideboards are available for purchase or they can be fabricated out of other materials, such as wood.

Sloped Sides (C-2): a permanent solution to maximize load hauling capacity. The degree of slope is determined by desired capacity. Additional accessories and options become available when selecting sloped sides.



D. Choose A Rear Tailgate Configuration

The final step when configuring your MARK E dump body rests in the rear tailgate. This decision will focus on your primary application.

Straight Tailgate (D-1): our most commonly selected style due to its array of flexible options. A great general purpose tailgate.

Also available in **Sloped** or **Asphalt Style** configurations.



An American Evolution Build A Dump Body All Your Own



Value Added:

It all starts with the ability to configure your dump body based on any number of criteria. Recognizing not all budgets, applications or types of loads are identical, we asked our engineers to provide real world solutions without sacrificing quality. They responded by delivering the **MARK E** line of dump bodies. Designed for both single and tandem axle chassis.

All **MARK E** dump bodies are built cross-memberless. The benefits behind cross-memberless are many: elimination of washboard floors, huge reduction in the number of corrosion points, lower center of gravity, reduced body weight, increased payload, steady load discharge and easy clean out.

It doesn't stop there. Henderson's unibody design goes the extra mile. We continued by overlapping the floor and side walls to spread impact and side load forces. Then capped it off by incorporating two I-beam longitudinals, which run the length of the body. From the core out, the **MARK E** dump body equates to unmatched strength, durability and quality.



Continuing to address wants and needs...

Select Your Grade of Steel

- Grade 50
- AR400
- AR450
- 201 Stainless
- 304 Stainless
- 409 Stainless

Accessories & Extras

- High Lift Tailgate
- Steps/Walk Rails
- Hydraulic Tanks
- Valve Enclosure
- Vibrator Mounts
- Ladders
- Tarp Shrouds
- Cab Shields
- Asphalt Lips
- Coal Chutes

Or mix-n-match, as needed.

And many more...

Cross-memberless & I-beam Longitudinals

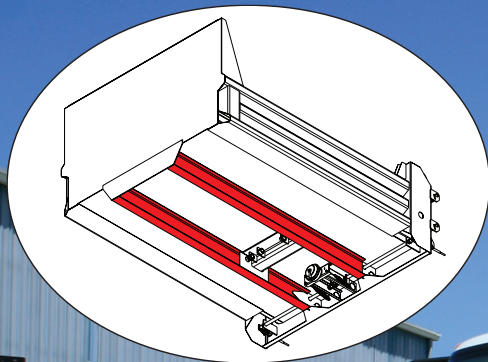

A dump body from the Henderson **MARK** Series is NOT just another dump body. Our willingness and ability to deliver a customized dumping experience, built around your specific operation, is what sets Henderson apart.

Choose a hoist, side/bracing, side slope, tailgate, grade of steel and from a list of additional options to dial in the perfect dump body. It's truly an American Evolution.

A Henderson **MARK** Series dump body is a long-term investment. When you're ready to incorporate the world's most customizable and durable dump body series into your fleet of work trucks, give us a call. As always, we stand by our claim as...

The Dependable Ones™



MARK E SINGLE AXLE DIMENSIONS & CAPACITY CHART

LENGTH	HEIGHTS (.in)			CAPACITY (cu. yd.) SIDES/ENDS	RECOMMENDED CA	TYPE	HOIST CLASS (NTEA)	CAPACITY (Tons)
	SIDES	HEAD	TAILGATE					
TELESCOPIC HOIST								
10'	24"	52"	32"	5.2/7.0	84	M90-4.5-3	50	21.5
10'	30"	52"	38"	6.5/8.3	84	M90-4.5-3	50	21.5
10'	36"	52"	44"	7.8/9.6	84	M90-4.5-3	50	21.5
10'	44"	52"	52"	9.6/11.3	84	M90-4.5-3	50	21.5
11'	24"	52"	32"	5.8/7.7	96	M100-4.5-3	60	21.6
11'	30"	52"	38"	7.2/9.1	96	M100-4.5-3	60	21.6
11'	36"	52"	44"	8.6/10.6	96	M100-4.5-3	60	21.6
11'	44"	52"	52"	10.6/12.5	96	M100-4.5-3	60	21.6
12'	24"	52"	32"	6.3/8.4	108	M110-4.5-3	60	17.5
12'	30"	52"	38"	7.9/10.0	108	M110-4.5-3	60	17.5
12'	36"	52"	44"	9.4/11.5	108	M110-4.5-3	60	17.5
12'	44"	52"	52"	11.5/13.6	108	M110-4.5-3	60	17.5
UNDERBODY HOIST								
10'	24"	52"	32"	5.3/7.1	84	7-17	50	14.2
10'	24"	52"	32"	5.3/7.1	84	8-17	50	18.7
10'	30"	52"	38"	6.6/8.4	84	8-17	50	18.7
10'	36"	52"	44"	8.0/9.7	84	8-17	50	18.7
10'	24"	52"	32"	5.3/7.1	84	8-21	60	24.1
10'	30"	52"	38"	6.6/8.4	84	8-21	60	24.1
10'	36"	52"	44"	8.0/9.7	84	8-21	60	24.1
10'	44"	52"	52"	9.7/11.5	84	8-21	60	24.1
11'	24"	52"	32"	5.8/7.8	96	8-21	60	21.4
11'	30"	52"	38"	7.3/9.2	96	8-21	60	21.4
11'	36"	52"	44"	8.8/10.7	96	8-21	60	21.4
12'	24"	52"	32"	6.4/8.5	108	8-21	60	19.2
12'	30"	52"	38"	8.0/10.1	108	8-21	60	19.2

*Consult your local Henderson Distributor, as CA and other installation related measurements may vary.
Additional accessories and options (not shown) are available.*

COMPLETE MUNICIPAL SNOW & ICE CONTROL SOLUTIONS

PLOWS • WINGS • UNDERBODY SCRAPERS • SAND & SALT SPREADERS • STANDARD & PRECISION SPINNERS • DUMP BODIES • COMBINATION (MUNICIPAL) BODIES
BRINE PRODUCTION & MANAGEMENT SYSTEMS • ANTI-ICE SYSTEMS • PRE-WET SYSTEMS • SLURRY SYSTEMS • COMPLETE TURNKEY PACKAGES



© Henderson Products, Inc., A division of Douglas Dynamics, L.L.C., reserves the right in pursuit of continuous product improvement to change specifications used herein. As a **custom manufacturer** of truck bodies, truck equipment and brine systems, additional product options may be available that are not shown here.



1085 S. Third Street, Manchester, IA 52057
Toll Free: (800) 359-4970
www.HendersonProducts.com

NJPA AWARDED CONTRACT
CONTRACT: 080114-HPI



HP-021 11/17